

水陸バックホウ20トンクラス作業範囲・外観図

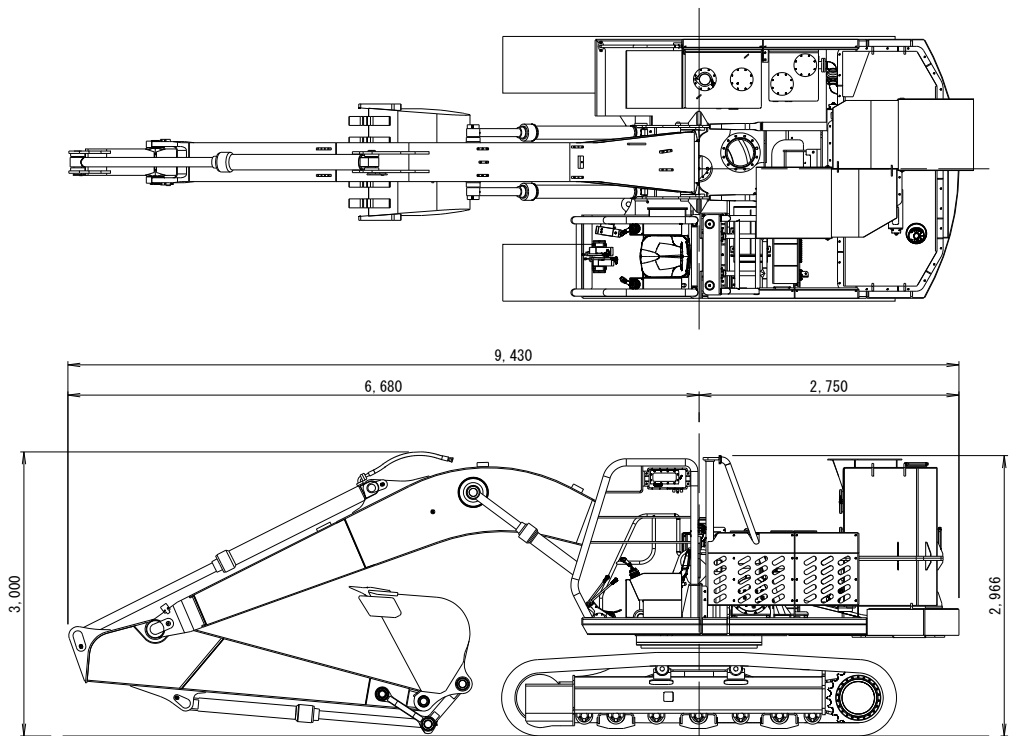

輸送姿勢
FIGURE OF TRANSPORTATION

トップダクト組合せ (8パターン)

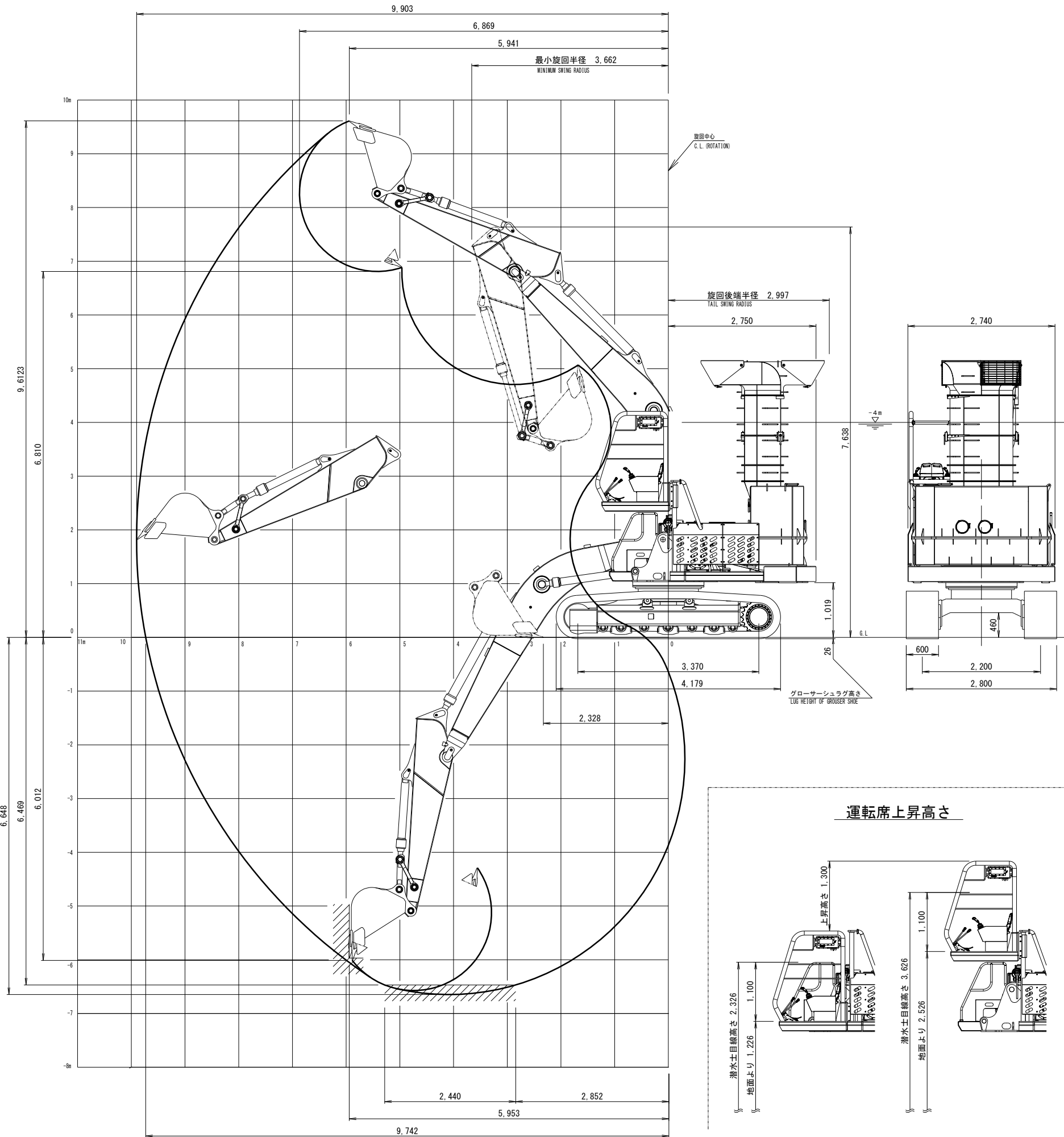
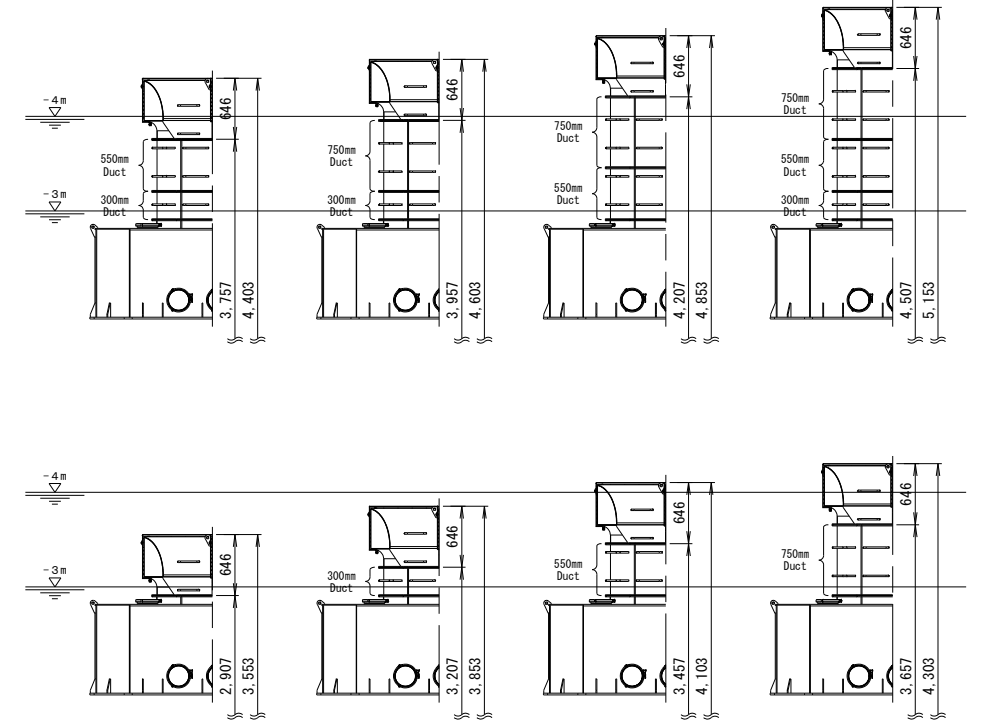

運転席上昇高さ

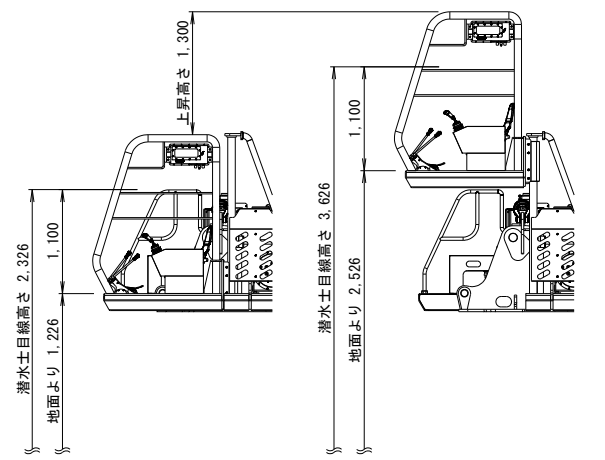

GROUP	919	PROJECT	TKM200-14 水陸両用バックホウ
APPROVED BY	A. UEYAMA	NAME	水陸バックホウ作業範囲・外観図
DESIGNED BY	K. TAMAKI	DWG. NO.	TKM214-B-GA-4S
Manufacturer Classification	(I)・S	SCALE	S=1:80
DATE	2021, 8, 12	極東建設株式会社 マリン開発部	