

水陸バックホウ20トンクラス作業範囲・外観図

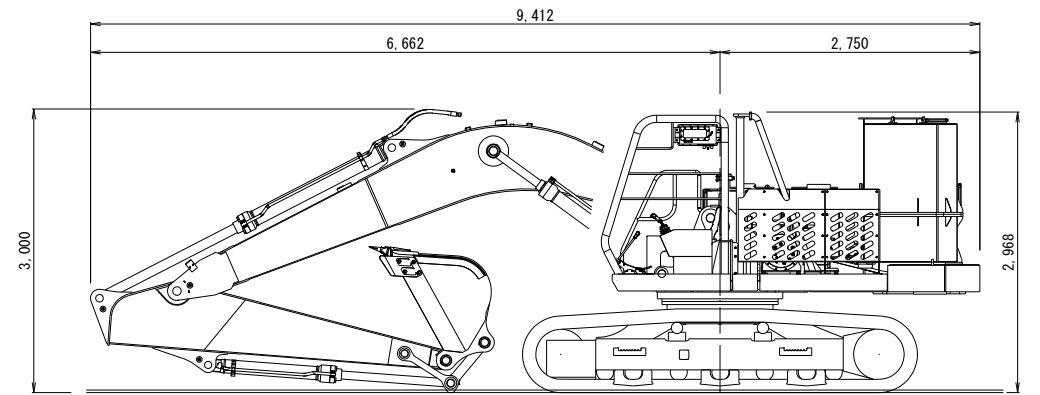

輸送姿勢
FIGURE OF TRANSPORTATION

トップダクト組合せ (8パターン)

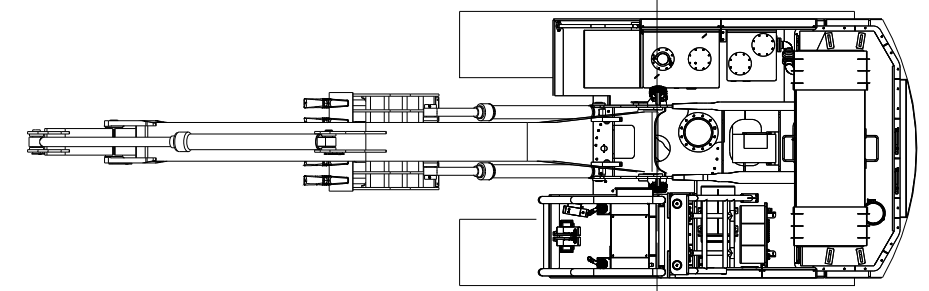
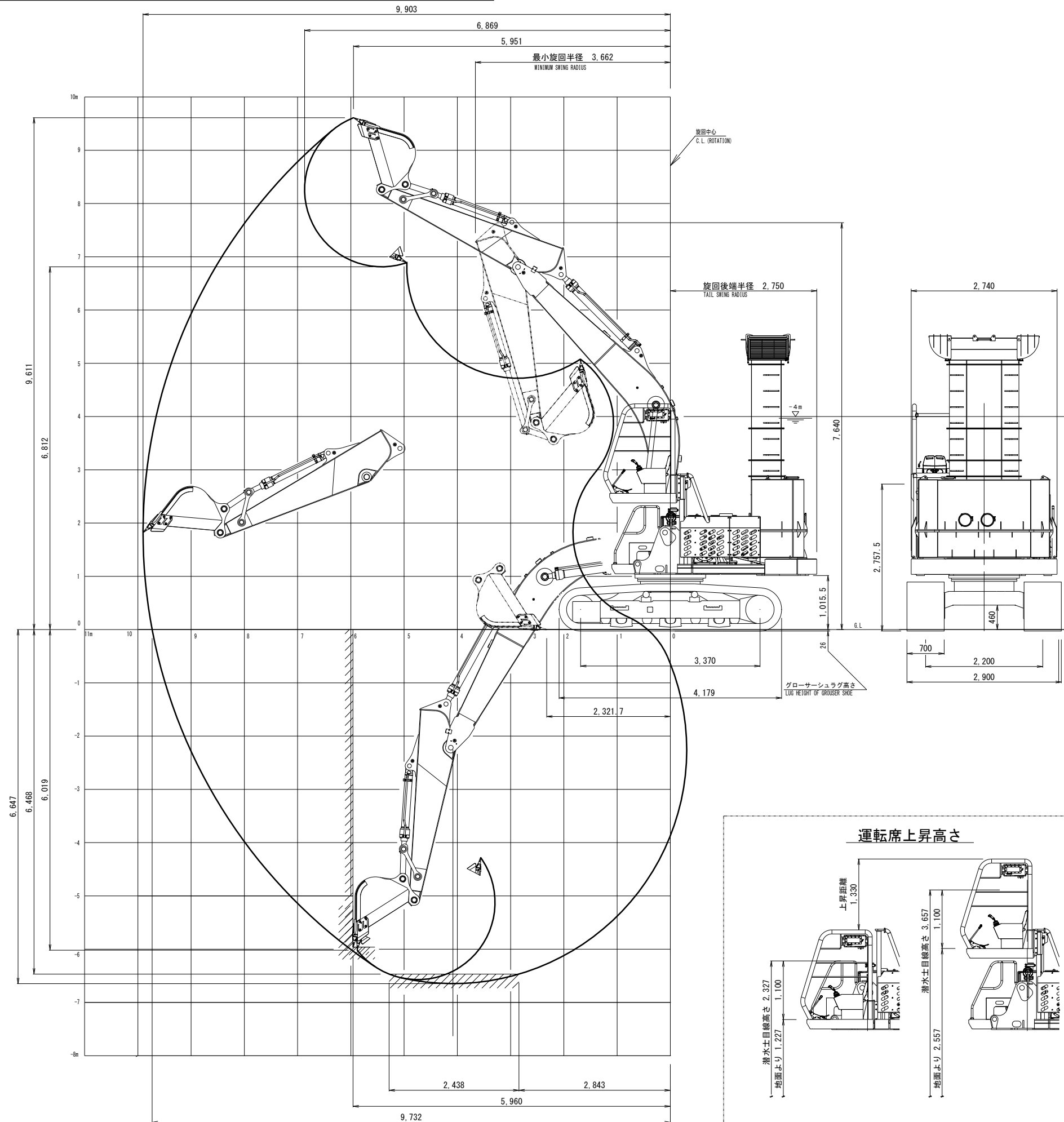

運転席上昇高さ

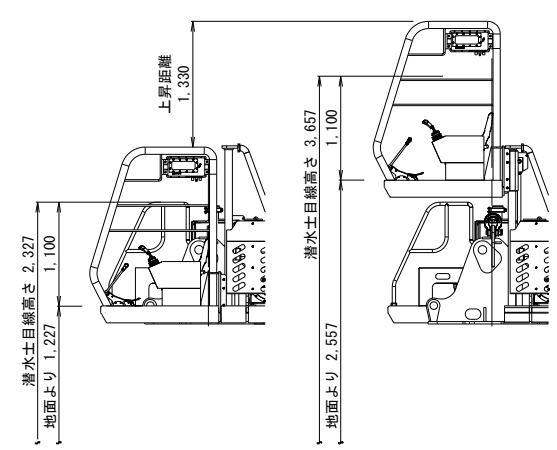

GROUP	998		PROJECT	TKM200-12 水陸両用バックホウ	
APPROVED BY			NAME	水陸バックホウ作業範囲・外観図	
DESIGNED BY	A.UEYAMA		DWG. NO	TKM212-B-GA-4S	
Manufacturer Classification	I・S		SCALE	S=1:80	
DATE	2018, 5, 10		極東建設株式会社 マリン開発部		